

The home of the turntable

THE VINYL ENGINE®

For more turntable manuals and setup information
please visit www.vinylengine.com

DENON

FULLY AUTOMATIC
DIRECT DRIVE TURNTABLE

DP-37F

OPERATING INSTRUCTIONS

Read instructions before use and retain for future reference.

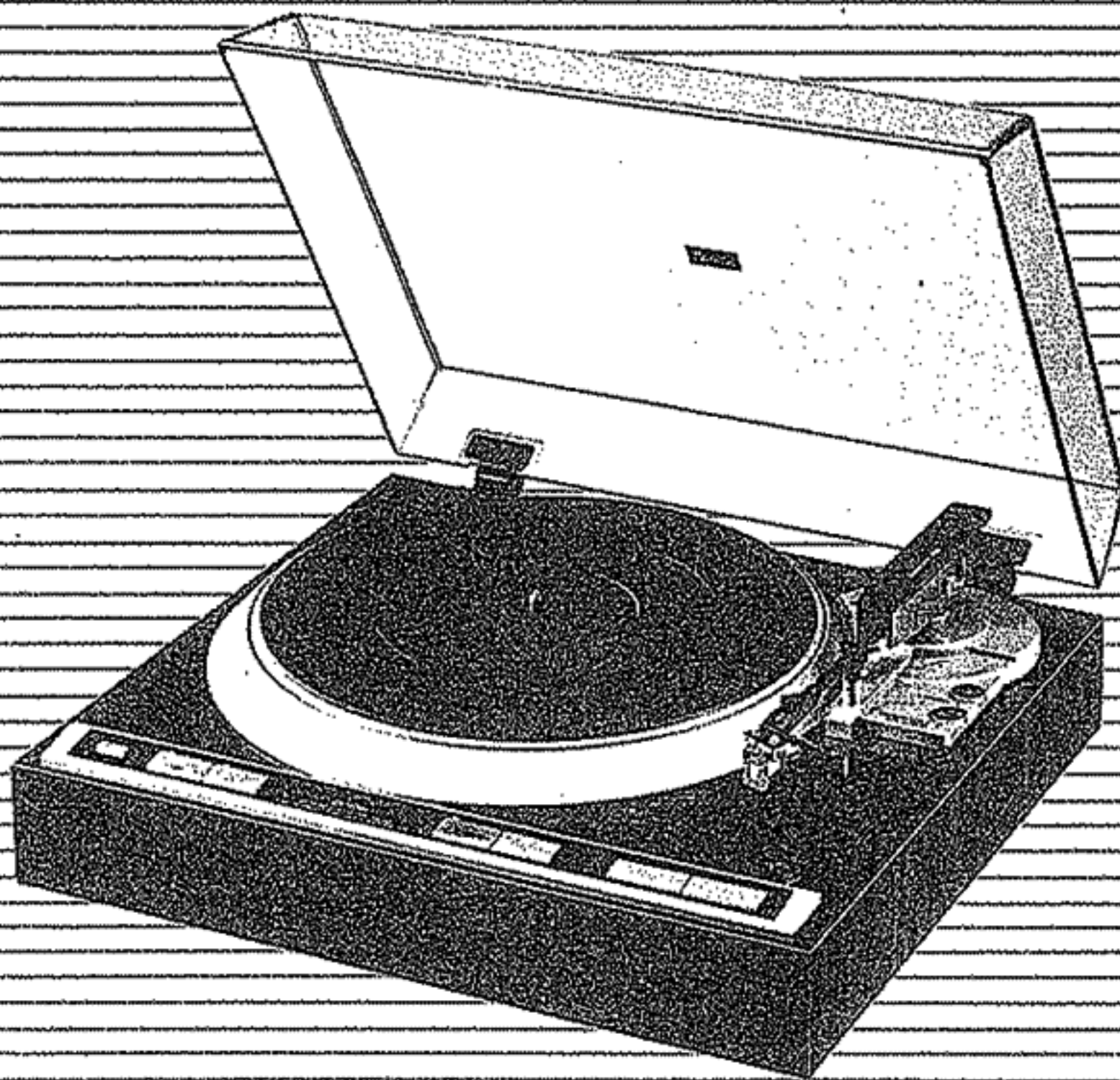

U.S. & Canadian models do not include Cartridge.

IMPORTANT TO SAFETY

WARNING:

TO PREVENT FIRE OR SHOCK HAZARD, DO NOT EXPOSE THIS APPLIANCE TO RAIN OR MOISTURE.

Model No. DP-37F _____ Serial No. _____

Please, record and retain the Model name and serial number of your set shown on the rating label.

(UNDERWRITERS LABORATORIES INC. (UL) LISTED MODEL FOR USA ONLY.)

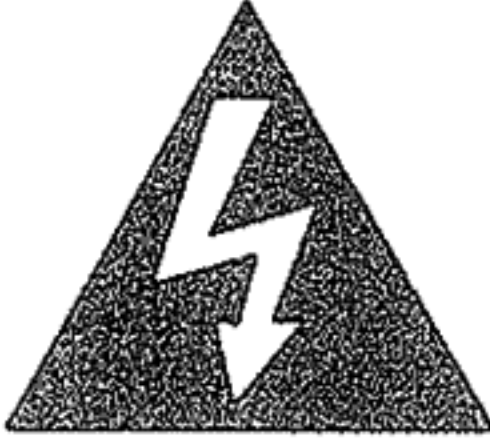

CAUTION

**RISK OF ELECTRIC SHOCK
DO NOT OPEN**

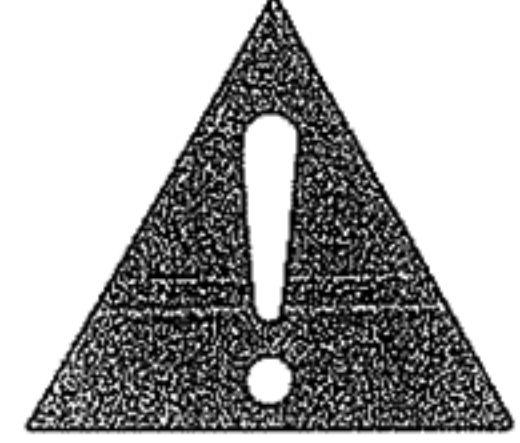

CAUTION: TO REDUCE THE RISK OF ELECTRIC SHOCK, DO NOT REMOVE COVER (OR BACK). NO USER SERVICE-ABLE PARTS INSIDE. REFER SERVICING TO QUALIFIED SERVICE PERSONNEL.



The lightning flash with arrowhead symbol within an equilateral triangle is intended to alert the user of the presence of uninsulated "dangerous voltage" within the product's enclosure that may be of sufficient magnitude to constitute a risk of electric shock to persons.



The exclamation point within an equilateral triangle is intended to alert the user of the presence of important operating and maintenance (servicing) instructions in the literature accompanying the appliance.

IMPORTANT (BRITISH MODEL ONLY)

The wires in this mains lead are coloured in accordance with the following code:

Blue:	Neutral
Brown:	Live

As the colours of the wires in the mains lead of this apparatus may not correspond with the coloured markings identifying the terminals in your plug proceed as follows. The wire which is coloured blue must be connected to the terminal which is marked with the letter N or coloured black.

The wire which is coloured brown must be connected to the terminal which is marked with the letter L or coloured red.

— TABLE OF CONTENTS —

FEATURES	3
PARTS NOMENCLATURE AND FUNCTIONS	4
HOW TO ASSEMBLE	5
HOW TO CONNECT	5
ADJUSTING THE TRACKING FORCE AND ANTI-SKATING FORCE	6
ADJUSTING THE Q-DAMPING	6
HOW TO PLAY	7
REPLACEMENT OF PARTS AND READJUSTMENTS	8
SPECIFICATIONS	9
TROUBLESHOOTING GUIDE	10

FEATURES

1. Microprocessor controlled, contactless servo tonearm

A unique microprocessor controlled, contactless servo tonearm ensures safe, easy to use automatic operation with no deterioration in sound quality.

2. Q-damping method (Dynamic servo tracer)

Low frequency resonance caused by the cartridge compliance and the effective tonearm mass is electronically damped both horizontally and vertically to effectively suppress crosstalk and inter-modulation distortion. The dynamic servo tracer maximizes the performance of the low mass tonearm and results in a record reproduction of excellent sound image with minimum noise and distortion.

3. Low mass straight arm

Having an outstanding tracing ability, this arm maximizes the performance of the high compliance cartridge to the full extent. Even with the most up-to-date high grade records, its tracing ability is excellent.

4. DENON quartz on bi-directional servo

The ultimate in rotational accuracy is realized by the combination of a magnetic pulse detector and a quartz lock, with the addition of a bi-directional servo.

Please check to make sure the following items, aside from the main unit, are packed in the carton.

- | | |
|--------------------------|-----------------------|
| 1. Turntable | 4. Overhang gauge |
| 2. Turntable mat | 5. Balance weight |
| 3. 45 rpm record adaptor | 6. Instruction manual |

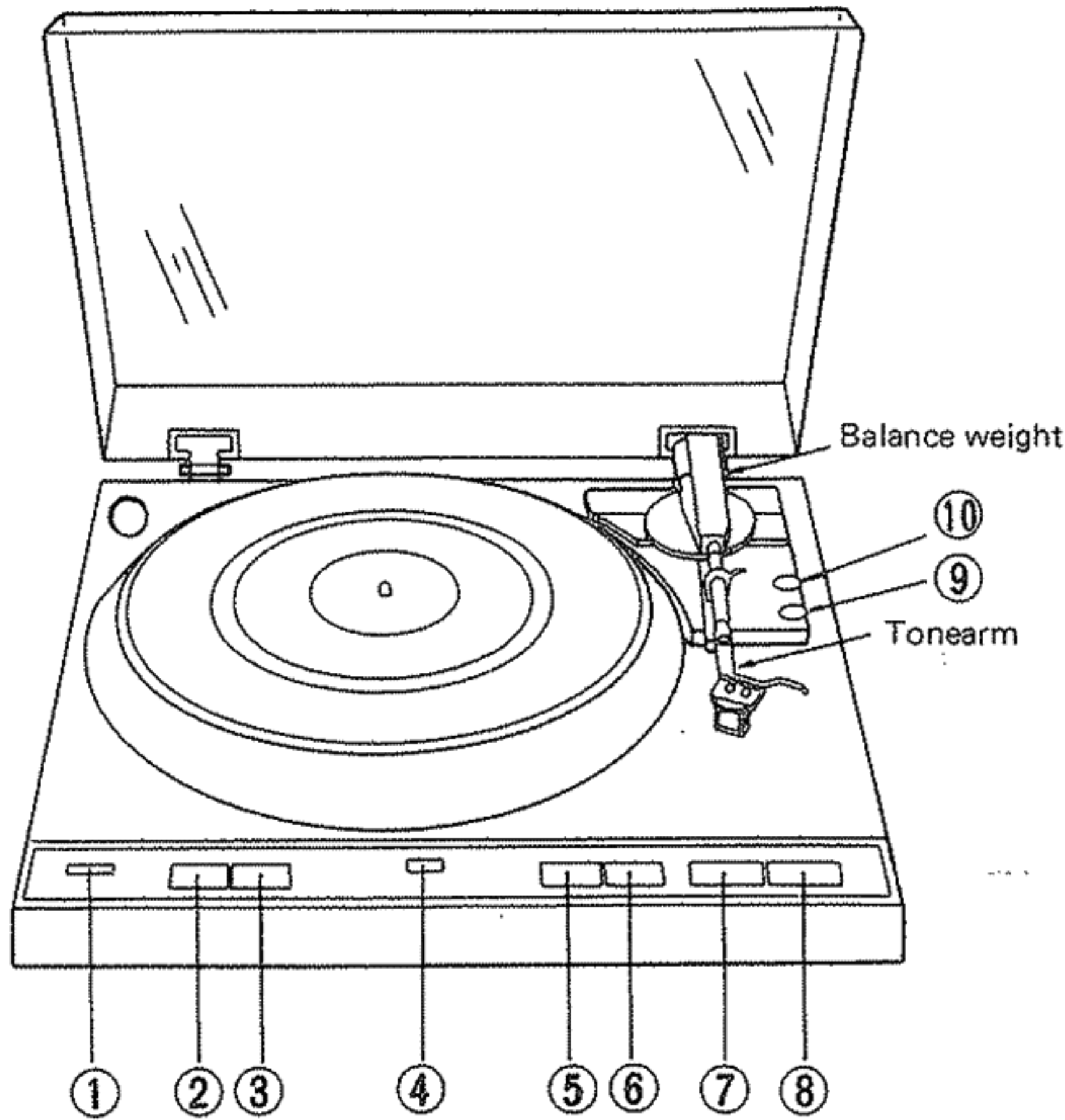
**1 Power switch POWER**

This turns the power supply on and off. Push the button down until it locks. When turning the power off, press the button until the lock is disengaged. Be sure to return the tonearm to the arm rest and hold it in with the clamp.

2 Size button SIZE

Before playing a record, press the button corresponding to its record size.

For 30 cm (12 inch) records, the (30) indicator will light.

For 17 cm (7 inch) records, the (17) indicator light.

3 Speed button SPEED

Before playing a record, press the button corresponding to its record speed.

The (33) indicator will light for 33 1/3 rpm records.

The (45) indicator will light for 45 rpm records.

4 Lock indicator LOCK

The lock indicator will light when the turntable speed reaches the specified phase-lock state.

5 Arm Lifter button UP LIFTER

Press this button to raise or lower the tonearm during play, or when playing records manually. The "UP" indicator will light up.

6 Repeat button REPEAT

Press this button for playing the same record repeatedly: the "ON" indicator will light up.

7 Start button START

Press this button to start records automatically.

8 Stop button STOP

Press this button to stop a record during play.

9 Tracking force adjustment knob**TRACKING FORCE**

This is used to adjust the tracking force. (Refer to page 6)

10 Q-damping adjustment knob Q-DAMPING

Refer to page 6.

HOW TO ASSEMBLE

1. Remove the packing material

Remove the packing material (styrofoam) attached to both sides of the cabinet.

2. Install the turntable platter and the turntable mat

Insert the turntable platter onto the motor shaft.

3. Attaching counterweight

Push in the counterweight at the rear end of tonearm. While pushing the counterweight, turn it in the arrow direction. After attaching, make sure that it moves back and forth by turning it.

Note: Be careful not to scratch the magnetic coating on the inner surface of the turntable. Further, avoid touching the diamond-cut (shiny) edge of the turntable platter with hands, as this may cause corrosion of the surface.

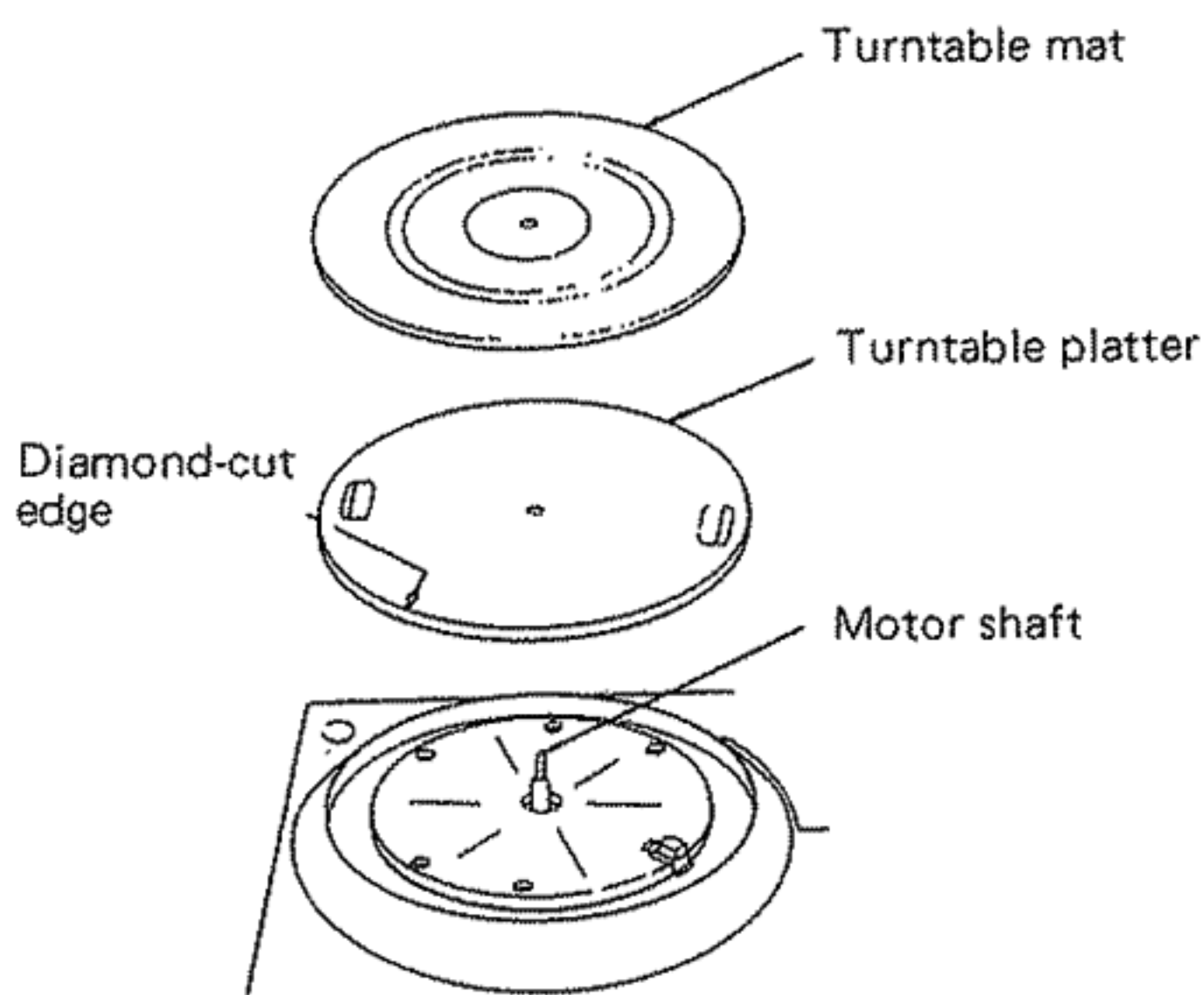

HOW TO CONNECT

1. Connect the left (L) and the right (R) output wires to the respective "PHONO" input terminals of the amplifier to be used.

Further, connect the ground wire (which is together with the output wires) to the "GND" terminal of the amplifier.

U.S. & Canadian models do not include cartridge. See page 8 for mounting cartridge.

2. Connect the AC power plug to an AC wall outlet.

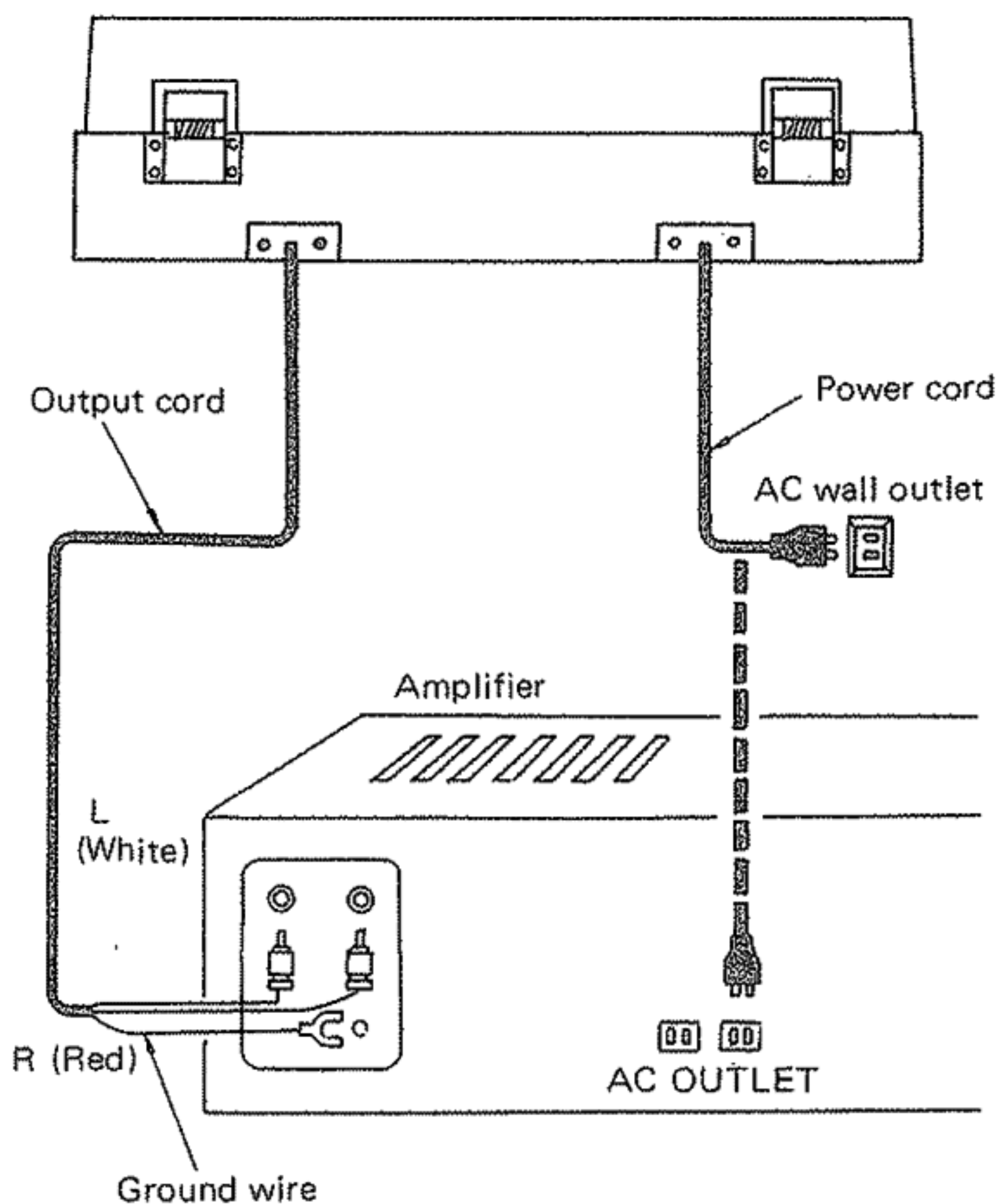

ADJUSTING THE TRACKING FORCE AND ANTI-SKATING FORCE

MAKE THE FOLLOWING ADJUSTMENT WITH THE POWER TURNED OFF.

1. Release the arm clamp

Hold the tonearm and lower the arm clamp in the direction of the arrow.

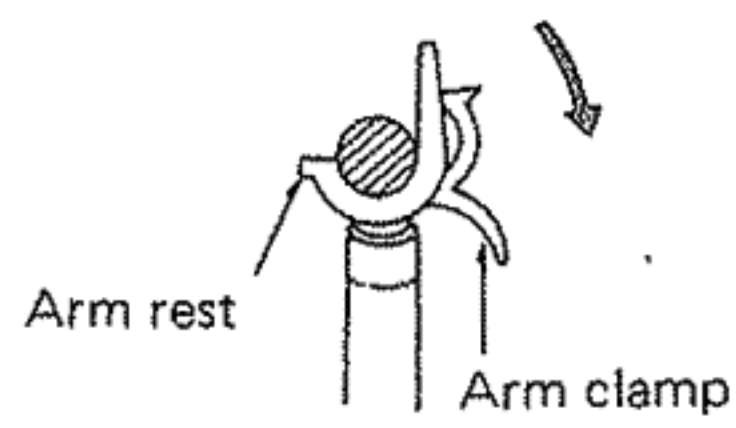

2. Move the tonearm

Take the tonearm off the arm rest and move it to a position between the arm rest and the turntable.

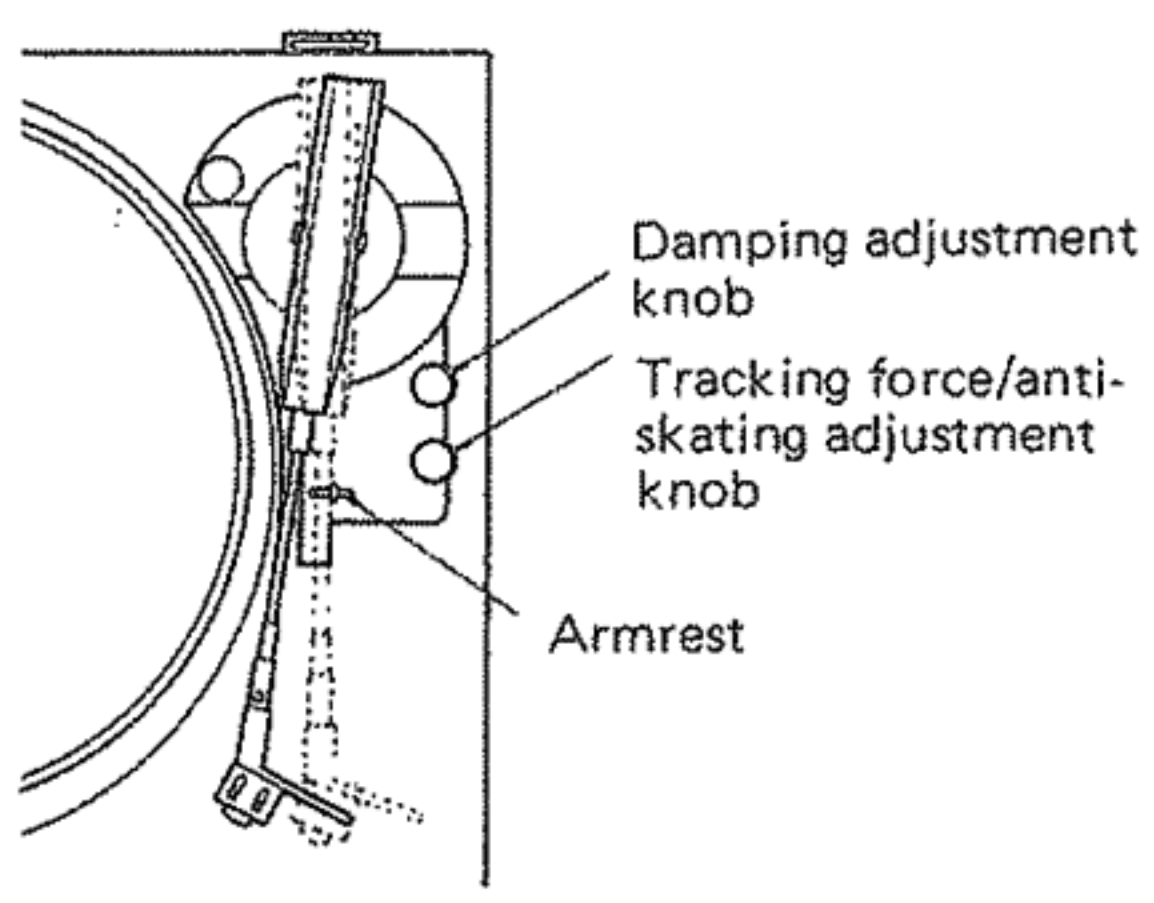

3. Balance the tonearm horizontally

Rotate the counter weight knob until the tonearm remains balanced parallel to the turntable surface.

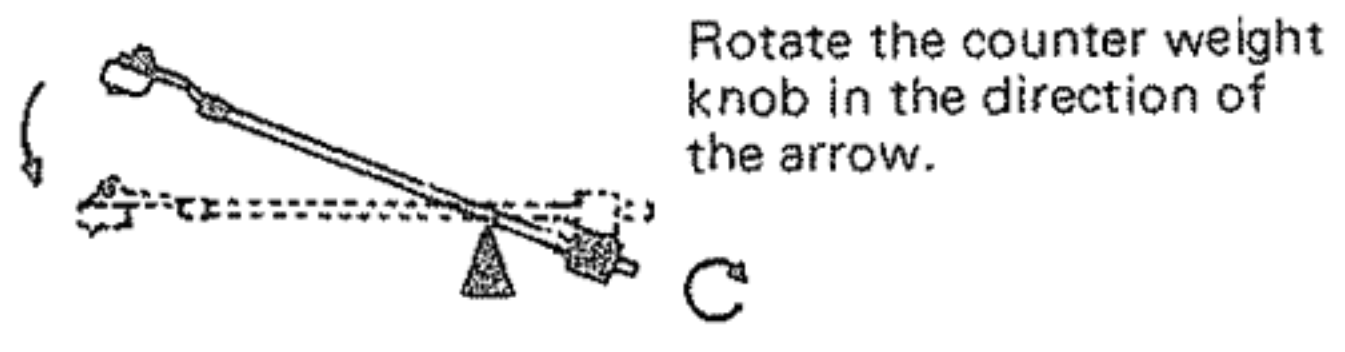
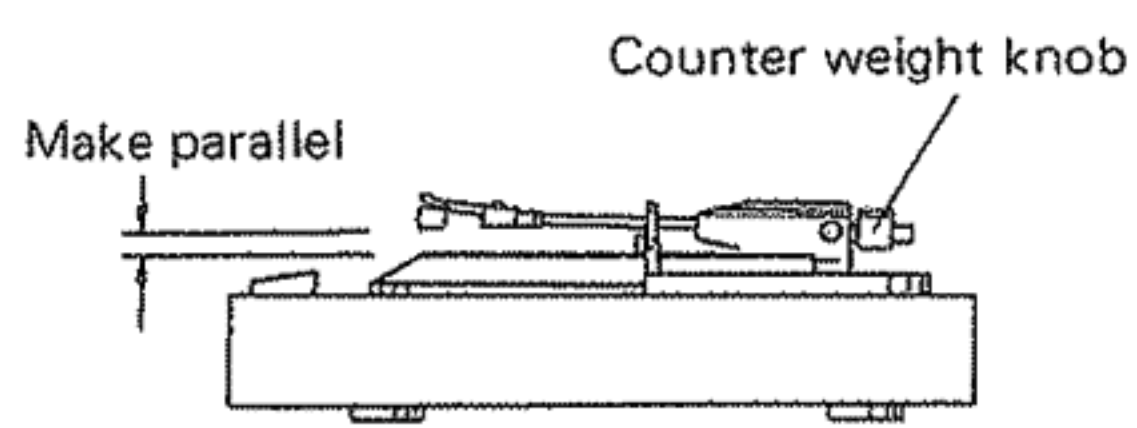

Rotate the counter weight knob in the direction of the arrow.

4. Return the tonearm to the arm rest

Return the tonearm to the arm rest and hold it in place with the clamp.

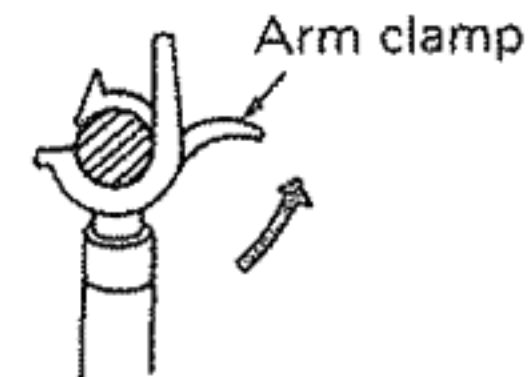

5. Adjust the tracking force and the anti-skating

Since the cartridge supplied with this turntable requires a stylus force of 1.8 g, rotate the stylus force knob and align the number 1.8 with the reference line. The anti-skating is automatically adjusted at the same time.

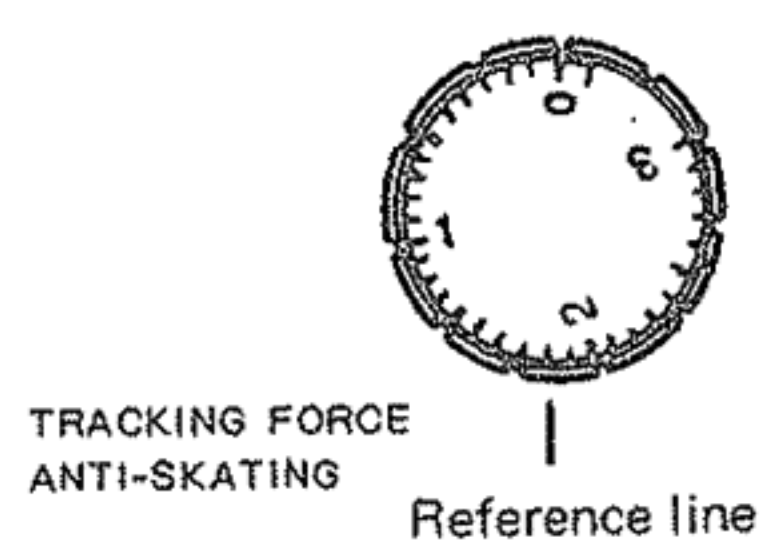

WHEN ADJUSTING THE TRACKING FORCE AND THE ANTI-SKATING

When using a cartridge other than the one supplied with this turntable, apply the suitable stylus force for it after consulting the cartridge instruction manual. The anti-skating is automatically adjusted at the same time.

ADJUSTING THE Q-DAMPING

Since the cartridge supplied with this turntable requires a Q-damping value of 1.8, rotate of 1.8, rotate the Q-damping knob and align the number 1.8 with the reference line.

- Although the optimum Q-damping value varies according to the cartridge compliance, this turntable is so designed that the optimum amount of damping can be obtained by setting the knob to the same value as that for the tracking force.

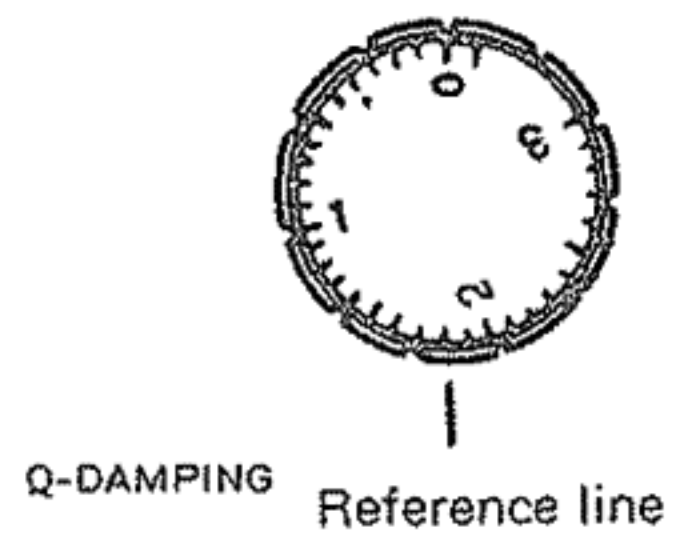

BEFORE PLAYING

1. Turn the power supply of the amplifier on, and set the selector switch/knob to "PHONO".
2. Place a record on the turntable and raise the stylus cover.
3. Turn the turntable power supply on, and press the speed selector button corresponding to the record speed.
33 1/3 rpm records
the (33) indicator will light.
45 rpm records
the (45) indicator will light.
4. Release the arm clamp.



FOR AUTOMATIC PLAY

1. Press the record size button corresponding to the record size.
30 cm (12 inch) records
the (30) indicator will light.
17 cm (7 inch) records
the (17) indicator will light.
2. Press the arm lifter button and lower the arm (after verifying that the "UP" indicator is not lit).
3. Press the start button.
The tonearm will move over to the record and play will begin.

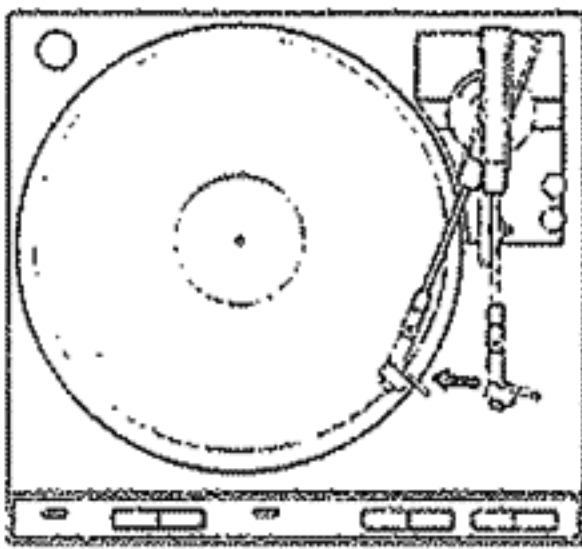

4. When the play finishes, the tonearm will return to the arm rest and the turntable will stop. (When the repeat switch is off). When the repeat switch is on ("ON" is lit), the record will be played again.

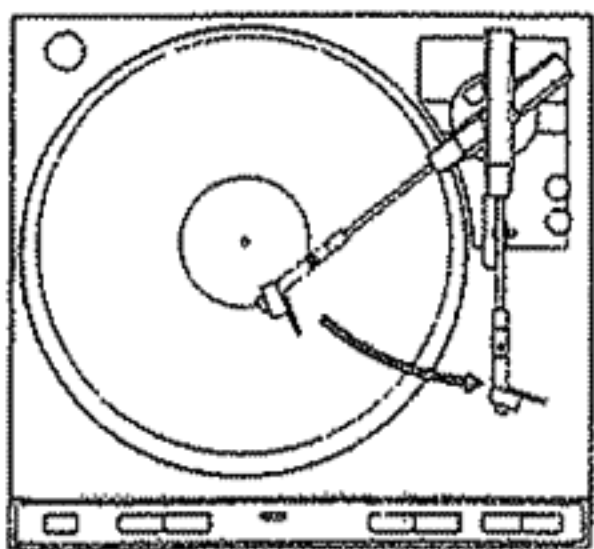

Repeat: OFF

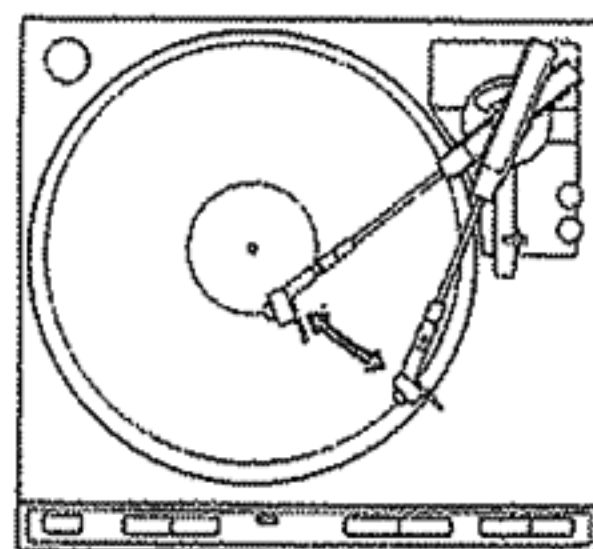

Repeat: ON

FOR MANUAL PLAY

- When playing records from the middle
- When playing non-standard size records

It is possible to play the records by the following 2 methods:

1st method:

1. Press the speed selector button corresponding to the record speed.
2. Set the arm lifter button to "UP" ("UP" will be lit).
3. Manually move the tonearm to the desired position above the record.

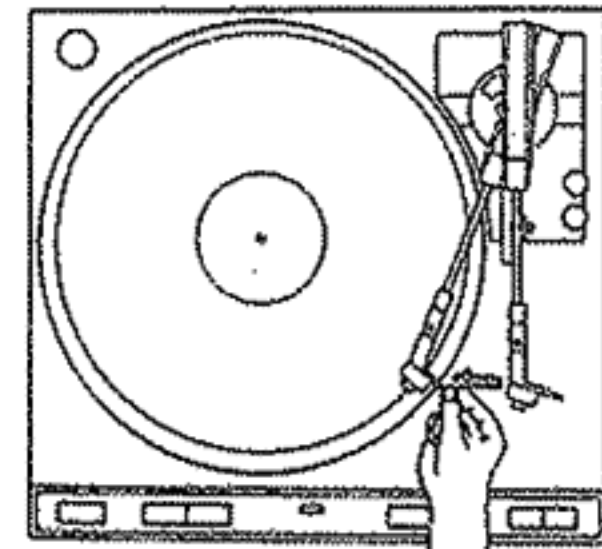

4. The turntable will start to rotate.
5. By pressing the arm lifter button, the tonearm is lowered and play will begin.
6. When play finishes, the tonearm will return automatically as in the automatic play mode.

2nd method:

1. Press the speed selector button corresponding to the record speed.
2. Manually move the tonearm towards the record and the turntable will start to rotate.

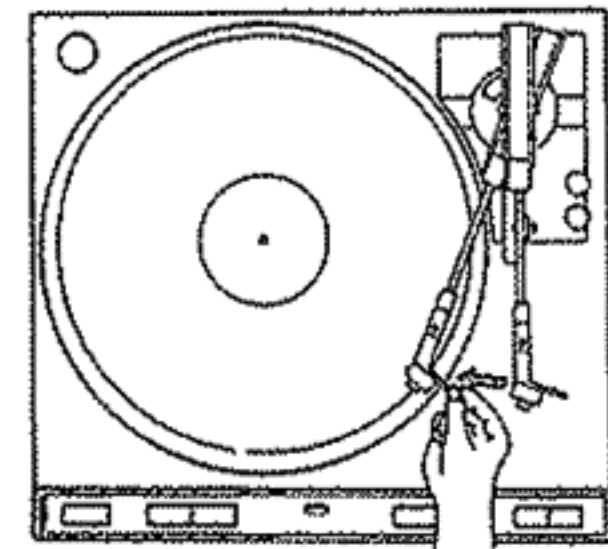

3. Set the stylus down on the record at the desired position and play will begin.
4. When play finishes, the tonearm will return to the arm rest and the turntable will stop.

REPEATED PLAY

Press the repeat button ("ON" indicator will light). The same record will be played repeatedly until the repeat is cancelled. To cancel the repeat, press the repeat button once more.

• When stopping during play

1. Press the stop button

The tonearm will return to the arm rest and the turntable will stop.

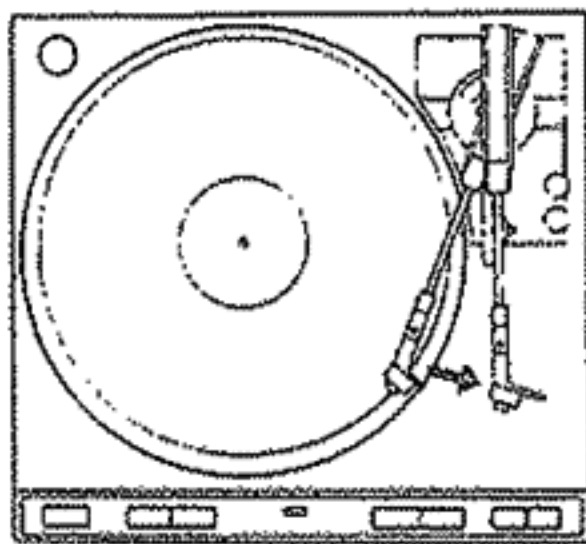

2. Or, press the arm lifter button to the "UP" position. The tonearm will rise at the position, while the turntable will keep rotating.

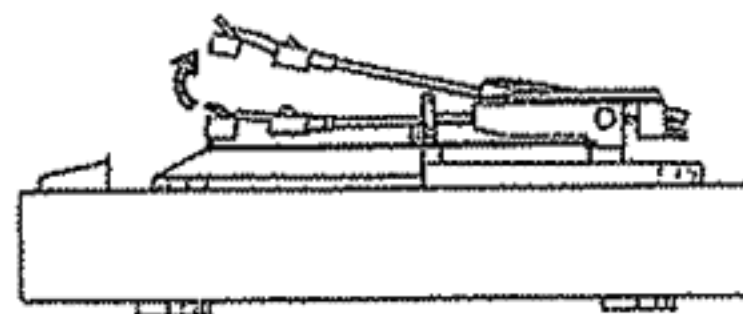

REPLACEMENT OF PARTS AND READJUSTMENTS

CARTRIDGE REPLACEMENT

A different cartridge with a weight between 4 and 9 g (including screws and nuts) can be attached to the head shell of this turntable unit. (When purchasing only the head shell, ask for the "DENON PCL-30BK".)

- The color designation of the lead wires is as follows. Be careful not to make any errors.

Red right channel (R)
White left channel (L)
Green right channel ground (RG)
Blue left channel ground (LG)

- Fit the attached overhang gauge as illustrated and bring the stylus tip on the cross line of the gauge. Tighten the screws making sure that the cartridge is parallel to the head shell. The proper overhang is thus obtained.

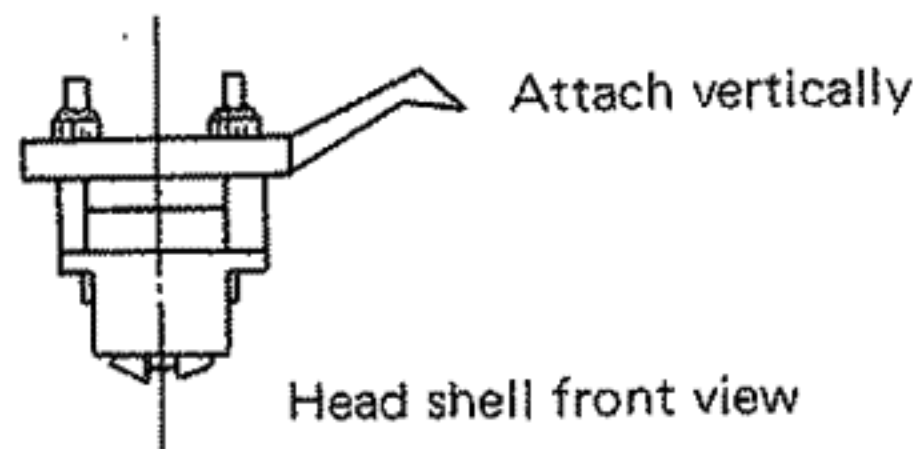
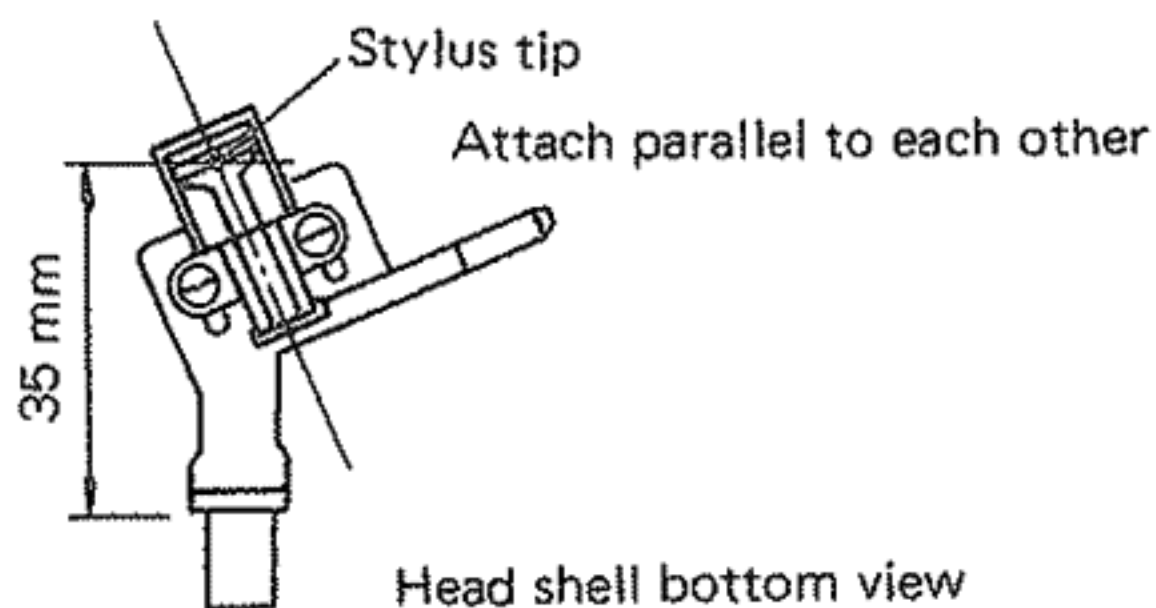
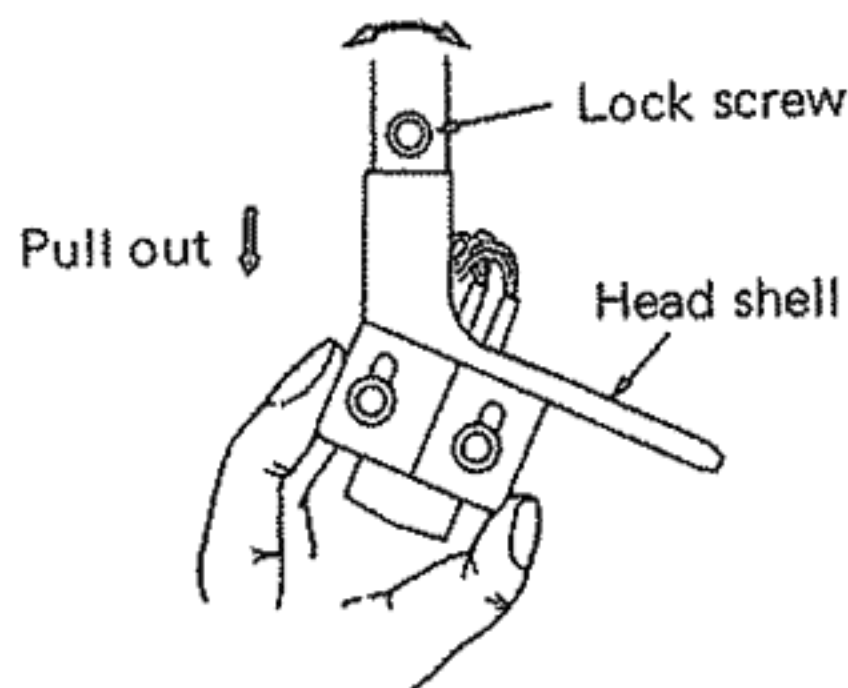
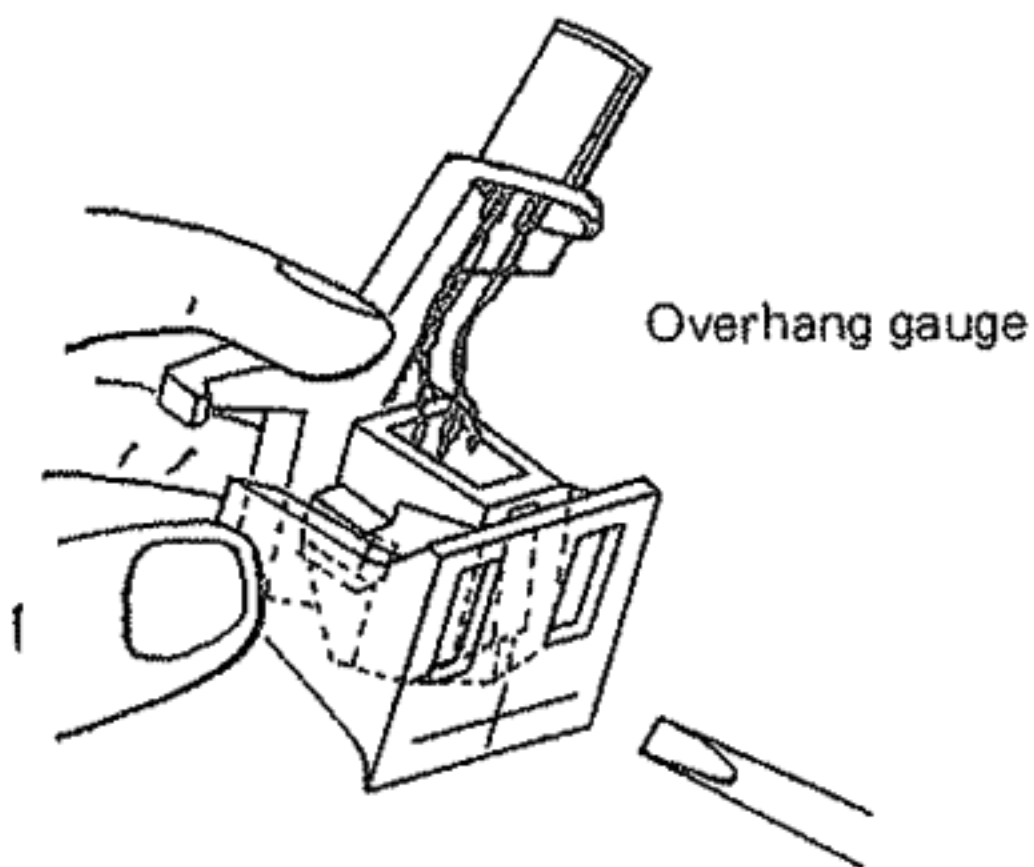

Note: When the cartridge has been replaced, be sure to readjust the horizontal balance, stylus force and Q-damping.

SPECIFICATIONS

PHONOMOTOR SECTION

Drive System:	Servo controlled direct drive
Turntable Speeds:	33-1/3, 45 rpm
Wow & Flutter:	Below 0.012% wrms (servo system) Below 0.020% (JIS)
S/N Ratio:	Over 78 dB (DIN-B)
Rise Time:	Nominal speed within 2 seconds (at 33-1/3 rpm)
Platter:	Aluminum die-cast; 300 mm diameter
Motor:	Linear drive motor
Speed Control System:	Speed servo by frequency detection, phase servo control
Speed deviation:	Below 0.01%
Load characteristics:	0% (80 g tracking force; outermost groove)

GENERAL

Power Supply:	50/60 Hz, Voltage is shown on rating label
Power Consumption:	8 W
Dimensions:	434 x 145 x 410 mm (W x H x D) 17 x 5.7 x 16.1 in
Weight:	Approximately 7.5 kg (16.5 lb)

TONARM SECTION

Arm Type:	Dynamically balanced, straight tube tonearm
Effective Length:	220 mm
Overhang:	16 mm
Tracking Error:	Within 3°
Automatic Mechanism:	Electronically controlled, fully automatic
Adjustable Tracking Force Range:	0 ~ 3.0 g (1 scale = 0.1 g)
Suitable Cartridge Weight Range:	Approximately 4.0 ~ 6.0 g (including screws, nuts)

Above specifications and outward appearance may be altered in future for improvement.

When trouble arises, check the following items before you consider any problem as a malfunction.

Turntable does not operate when start button is pressed.

The tonearm does not move:

- ⊗ Is the power switched on?
- ⊗ Is the arm clamp released? Refer to page 6

The stylus does not lower onto the record:

- ⊗ Is a stylus force being applied? Refer to page 6

The stylus does not lower on the desired position:

- ⊗ Is the cartridge properly installed on the head shell? Refer to page 8
- ⊗ Is the turntable unit placed horizontally?

No sound

- ⊗ Are the cartridge and the tonearm connected properly? Refer to page 8
- ⊗ Are the output wires properly connected to the amplifier? Refer to page 5
- ⊗ Are the amplifier knobs/switches properly set for record reproduction?

Hum noise is audible:

- ⊗ Is the ground wire of the output wires connected to the amplifier? Refer to page 5
- ⊗ Are the output wires properly connected?
- ⊗ Is the head shell secured properly with the lock screw? Refer to page 8

The stylus skips/Jumps

- ⊗ Is the stylus force applied properly? Refer to page 6
- ⊗ Is the record warped or scratched?
- ⊗ Is there any large amount of dust on the stylus?

The arm stops moving forward during play:

- ⊗ Is the record scratched?
- ⊗ Is something touching the arm?

Sound is too weak/strong:

- ⊗ Is the amplifier switched and connected properly for the type of cartridge (output) being used?

Noise is picked up by the tuner:

- ⊗ Should the tuner pick up noise while the turntable unit is in operation, move the tuner away from the turntable, or relocate the tuner antenna.

The tonearm moves up and down when power is switched on:

- ⊗ The up and down movement of the tonearm when the power is switched on/off is not a defect.